



Clean Feed Output Module

This addendum will guide you through installation and use of the Clean Feed Output Module. The following topics are covered:

- Introduction
- GlobeCaster Requirements
- Electrostatic Discharge Reminder
- Installing the Card
- Connectors on the Clean Feed Output Module
- Settings Panel in GlobeCaster
- Technical Specifications



Introduction

GlobalStream's Clean Feed Output Module (34-725-00) allows the main program out of the GlobeCaster to be tapped off before a final DSK overlay and presented as a separate output. Here are some features of the Clean Feed Output Module:

- Allows users to output the program before additional graphic layers are composited
- Program output in GBR (w/ or w/o sync), YUV (Betacam), or YC (S-video) and composite (three BNCs)
- Fourth output is composite out
- YC (S-video) connector for convenience (only for use in YC (S-video) mode)
- Can output program alpha (key) signal (all 4 outputs switch together)
- Built in fade to black function
- Supports NTSC, PAL-M (525 line); PAL, PAL-N (625 line)
- 27MHz oversampling 10 bit D to A converters
- Sync pulses, burst envelope, etc. in accordance to appropriate world standards (SMPTE 170M, ITU-R BT.470)
- Can pass super-black, or over range signals
- Vertical interval pass or force blanking
- Setup can be selected by user
- Timing compatible with Analog Multiformat Master out
- Timing is adjustable +/- 2uS from Analog Master

GlobeCaster Requirements

- Your GlobeCaster must have at least one DSK card installed in order for the Clean Feed Output Module to work.
- You must also be running GlobeCaster software version 2.8.2. The latest software build is available online at www.globalstreams.com.

Installing the Card

Before you install the Clean Feed Output card, it is important to make a point about electrostatic discharge, or ESD. Even if you are an experienced technician, you should be aware of the danger of ESD.

Almost everyone is aware of static electricity and its effect when you rub your feet on the carpet and zap someone on the earlobe. But did you know how damaging static electricity can be to computer components?

For a human being to feel a static shock, the voltage must be around 1,500 volts. Really nasty shocks can be over 30,000 volts! Electronic components can be damaged by much lower voltages, about 20-30 volts. Therefore the static electricity your body accumulates is enough to damage circuit boards by merely touching them.

Sometimes ESD damage is not readily apparent, and can cause a board to fail months after it was improperly handled. To avoid this type of failure, please take the following steps when working inside your GlobeCaster:

- Remove any articles of clothing that gather static electricity.



- Work on the GlobeCaster in a reasonably ESD-free area.
- When working on the GlobeCaster, keep it turned off and unplugged.
- Before touching any boards inside GlobeCaster, touch the edges of the chassis *lightly* to discharge any static buildup you may have.
- Handle only the boards you need to handle. Don't go poking around in the unit without a reason.

An ESD wrist strap costs \$5 - \$20 at any electronic supply house, and ensures that your body does not have any static charge. Having an ESD wrist strap is recommended, but not required. Attach the alligator clip of the wrist strap cord to the Trinity chassis or another common ground point.

Proper Placement Within GlobeCaster

The Clean Feed Output module should be placed directly behind the card that will be used to overlay the final layer (the one that will not be seen on the clean output). If there are any additional DSK cards downstream of the one with the Clean Feed module, their layers will also not be seen on the clean out. If there are any DSK cards upstream of the Clean Feed module, they will operate normally and their DSK layers will be seen on both the clean out and the main program out.

To install the module, follow these instructions:

1. Turn off the power to the GlobeCaster.
2. Unscrew the three thumbscrews along the edge of the top cover.
3. Slide the top cover toward the back of the GlobeCaster about halfway, and lift off.
4. Locate the lockdown panel that holds the backs of the cards in place. It is on the inside of the back of the unit. It is hinged in place, and held down with three thumbscrews, see the following figure 1.1.

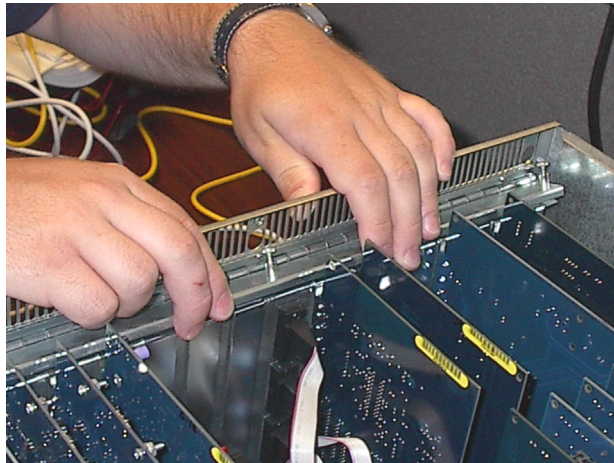

Figure 1.1: Rear Lockdown Panel

5. Unscrew the three thumbscrews on the rear lockdown panel.
6. Lift and rotate the lockdown panel out of the way.
7. Remove the backplate from the hole in the back of the slot.
8. Line up the new card in the socket.
9. Push lightly down on the card, **BUT DO NOT PUSH THE CARD IN YET!** Double-check a second time to make sure that the card is properly aligned and not binding within the socket. **PLEASE NOTE: THESE HIGH SPEED SOCKETS ARE MUCH MORE FRAGILE THAN STANDARD PC SOCKETS AND EXTREME CARE MUST BE TAKEN TO MAKE SURE THAT THE MOTHERBOARD IS NOT DAMAGED DURING INSTALLATION.**



10. Using equal pressure, push the card into the socket. Make sure the card is in the socket evenly.
11. Rotate the rear lockdown panel back into place, and tighten up the thumbscrews.
12. Replace the retaining bar and tighten the thumbscrew on it.
13. Replace the top cover. Make sure the bottom edges of the top cover fit into the slots on the bottom cover.
14. Tighten the three thumbscrews on the top cover.

Connectors on the Clean Feed Output Module

This card can output YUV at Betacam levels and RGB (sync on green) at SMPTE levels. It also has an option for Composite/YC mode. The S-video connector on the card is only active if the card is in Composite/YC mode.

Here are the functions of the connectors:

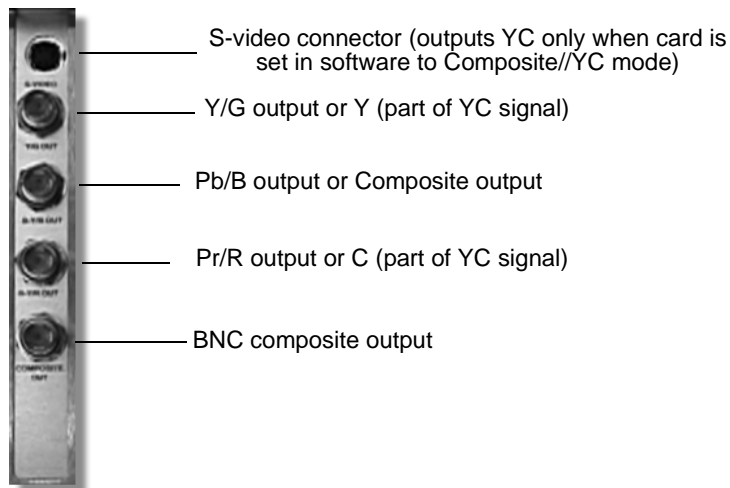

Figure 1.2: Connectors

Header on Module

The Clean Feed Output module contains a shrouded header that can be used as a connection to another input card. Simply attach a video header ribbon cable from the header on the Clean Feed Output module to another input card. Connecting to another input card can provide the following advantages:

- Lets you record the clean feed out to the Time Machine
- Creates an auxillary recursive path
- Uses digital connection, not analog
- Can be used as another connection, freeing up the external inputs on the back of the card
- Certain input cards can provide color correction via the header path: Serial Digital Input Card, DV, and Analog component

Settings Panel in GlobeCaster

A new settings panel is associated with the Clean Feed Output Module. To access this new panel, click on the **Configure** button in either **Switcher** or **Editor**. Select **Input Settings** from the drop-down menu, the following panel is displayed.

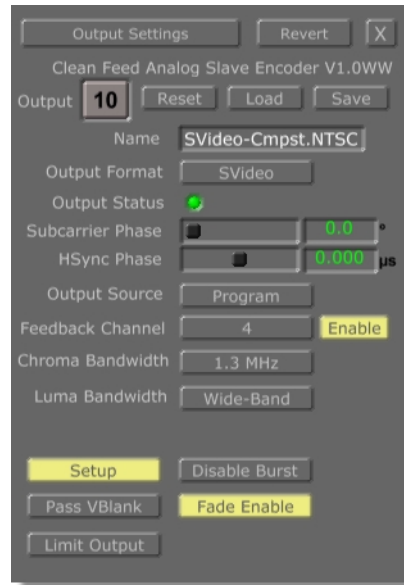

Figure 1.3: Clean Feed Settings Panel

Let's take a look at the buttons and sliders on the Clean Feed settings panel.

Output Settings	Displays the Output Settings drop-down menu.
Revert	Resets the values to the last values you saved.
X	Closes the settings panel.
Output	Selects the output card being adjusted.
Reset	Resets the values to the default settings.
Load	Brings up a pop-up list of existing output settings profiles.
Save	Saves the current values as a profile.
Name	Shows the name of the profile. Be sure to type in a new name here when creating a new profile, or you won't be able to save it. This is so you can't overwrite the factory pre-sets and will always have a basic set of values to work with.
Output Format	Click on this button and select the desired output format from the pop-up menu.



Output Status	<p>Refers to this card's output only.</p> <p>A yellow or red light indicates a problem with the signal, usually related to genlocking. Right-clicking on the light brings up a window with a message regarding the nature of the problem.</p>
Subcarrier Phase HSync Phase	<p>These adjustments are relative to the phase of the master output. If the master output is adjusted, it adjusts the phasing of the slave output by the same amount. Adjusting these phases independently of the multi-format (component) master encoder may be useful to compensate for unequal cable lengths, or in the case of key out, to adjust the key signal to align with the content. Note that the composite master encoder card has a shorter delay, and the analog slave's output does not have enough range to match it (it will run slightly behind).</p>
Output Source	<p>Select either Program or Clean. This will allow you to choose to have a Program out or Clean out.</p>
Feedback Channel	<p>Displays the slot number of the input card to which the Clean Feed output card is connected. The Clean Feed output card can be connected to another input card by connecting a ribbon cable to both card's headers.</p>
Enable	<p>Toggle button that enables you to use the Clean Feed out or to use the backpanel input. When you select Enable, the number on the video bus that corresponds to the slot number is augmented with a superscripted 1, 2, or 3 depending on what Clean Feed Module is being used. See Switcher down below for more information.</p>
Chroma Bandwidth	<p>Allows you to tailor the bandwidth of the color information. Can be set to 1.3 MHz, 2.0 MHz, 1.0 MHz or 650 kHz. To be absolutely sure the signal is within NTSC specs, set the bandwidth to 650 kHz. There is an advantage in color quality to bumping this value up to 1.3 MHz. Wide bandwidth (1.3 MHz) gives you sharper color definition, but also has a greater chance for dot crawl on older monitors. Narrow bandwidth (650 kHz) is used on older equipment. The colors are fuzzier and less defined, but there is a lower chance of seeing dot crawl in the output. Generally it is OK to use the 1.3 MHz bandwidth. The correct setting for PAL is always 1.3 MHz. For component signals, the recommended setting is 2.0 MHz.</p>



- Luma Bandwidth** The wider the luma bandwidth, the better the image quality. But if there is too much information in the signal, it can bleed into the audio signal when transmitting. A rule of thumb is, if broadcasting the signal, set this to **Low-Pass**; otherwise, set it to **Wide-Band**. **Low-Pass** may also be useful when sending to an MPEG CODEC (for streaming video applications).
- Setup** Makes some subtle changes to the black level of the signal. The Setup modifier is kind of a throwback to old 1950s and 1960s television. It is either turned on or off. Most modern equipment does not require **Setup**, but NTSC equipment usually expects it to be there. Unless you know for a fact it is not being used, leave it on for NTSC. It should be off for PAL.
- Disable Burst** Turns off the color burst in the signal. If you ever wish to harken back to the days of yesteryear and work with a true monochrome video signal, turn **Disable Burst** on.
- Pass VBlank** If this button is off, any data stored in the vertical blanking interval, such as time code or closed captioning, is lost. This can be handy if the footage you are working with is only partially closed-captioned, and you wish to strip out the existing closed captioning and start fresh. Or you may wish to blank out the time code or closed captioning on a video projector during a live event. When this feature is turned on (is passing on the vertical blanking information), **Fade** to black does not affect it. The vertical blanking signal on the Program bus is the signal passed to the output.
- Fade Enable** Controls whether this particular output fades to black when that button is pressed in Switcher. By turning the button off on a slave output encoder and leaving it on in the master output encoder, only the master output fades to black. This gives you added flexibility when sending a program feed to several different sources.
- Limit Output** Limits digital video to digital range of 16-235. When off, allows superblack or over range signals to be passed.

Switcher

When the **Enable** button is selected in the **Settings** panel, the button in the video buss that corresponds to the slot number is augmented with a superscripted number. Notice in figure 1.4 how the 4th slot has the superscripted number. This means that your first Clean Feed Module is connected to input card in the fourth slot.



Figure 1.4: Buttons on Switcher

Technical Specifications

Here are the technical specifications for the Clean Feed Output Module.

Signal to Noise	<p>Luma noise</p> <ul style="list-style-type: none"> -64 dB rms (100IRE unmodulated ramp, unweighted, 10KHz-5MHz) -70 dB rms (100 IRE unmodulated ramp, unified weighted, 10KHz-5MHz) -77 dB rms (pedestal, unweighted, 10KHz-6.5MHz) <p>Chroma noise</p> <p>Amplitude: -70dB (red field, 10KHz high pass)</p> <p>Phase: -68dB (red field, 10KHz high pass)</p>
Differential Gain	0.5%, 1.0% Max.(40 IRE ModRamp)
Differential Phase	1.0 deg., 1.5deg. Max.(40 IRE ModRamp)
Luma Nonlinearity	+/- 0.5% (luma ramp) (1% p-p)
K Factor	0.3%, 0.5% max.
Chroma Gain Nonlinearity	+/- 1.0%
Chroma Phase Nonlinearity	+/- 0.6 deg.



Chroma-Luma Delay Error	+/- 1 nS
Chroma-Luma Gain Error	+/- 0.6% (composite out)
Output Level Error	+/- 1% (luma/green out, on board trim)
Channel to Channel Matching	+/- 1% (referenced to luma/green, trim affects all 3 channels)
Luma Bandwidth	5.0MHz (+/- 0.2dB, -1dB ~5.75MHz, wideband mode)
Chroma Bandwidth (applies to composite and component outs)	narrow: 650KHz (-3dB) medium: 1.0MHz (-3dB) wide: 1.3MHz (-3dB) widest: 2.0MHz (-3dB)
Timing Range	+/- 2uS (from Analog Multiformat Master, 37nS steps)
Subcarrier Phase Range	360deg (1.4deg. steps)

